

Sensors

Prof. Dr. M. Zahurul Haq
zahurul@me.buet.ac.bd
<http://teacher.buet.ac.bd/zahurul/>

Department of Mechanical Engineering
Bangladesh University of Engineering & Technology

ME 361: Instrumentation & Measurement



Measurement Specification

- **Resolution** refers to the smallest change in the measured variable that can be detected by the sensor.
- **Accuracy** refers to the difference between the actual value and the measured value.
- **Repeatability** refers to the average error between consecutive measurements of the same value.

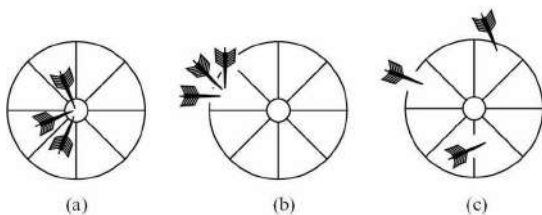

e476 .eps

- (a) Accurate
- (b) Repeatable but not accurate
- (c) Not repeatable not accurate



3 Basic Phenomenon in Effect in Sensor Operation

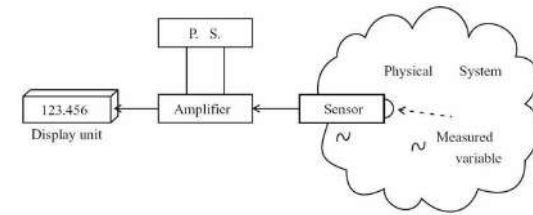

e453 .eps

- 1 Change (or the absolute value) in the measured physical variable (i.e. pressure, temperature, displacement) is translated into change in sensor property (resistance, capacitance, magnetic coupling). This is called the *transduction*.
- 2 Change in the sensor property is translated into low-power-level electrical signal in the form of electrical voltage or current.
- 3 Low-level-power sensor signal is conditioned and transmitted for processing i.e. display or for use in control systems.



Input-Output Model of Sensors

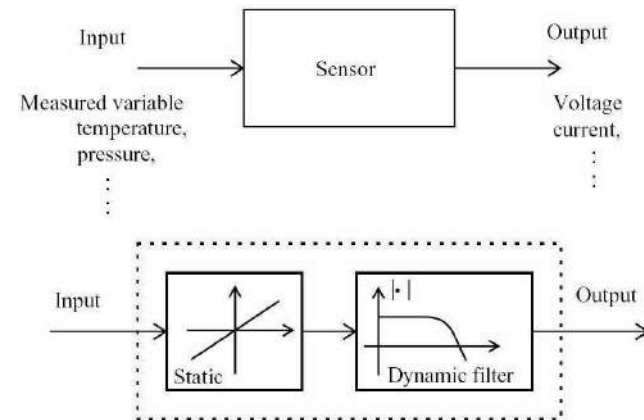

e477 .eps

Dynamic response of a sensor can be represented by its frequency response or by its bandwidth specification



Non-linear Variation of Input-Output Relationship

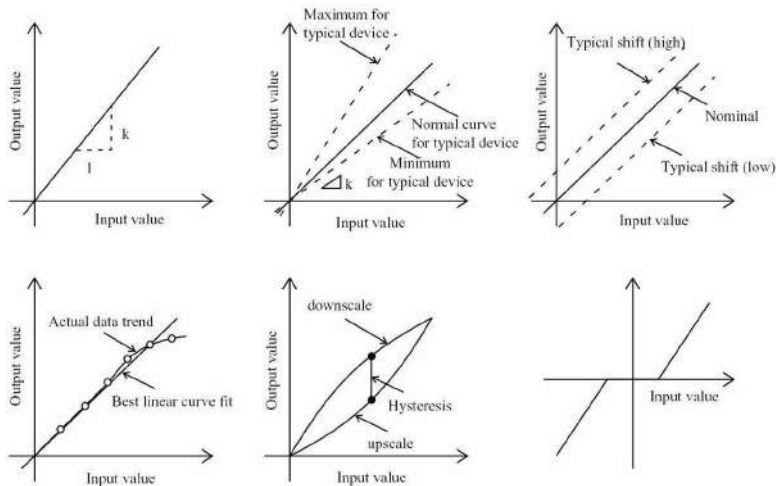

e478.eps



Resistive Sensors

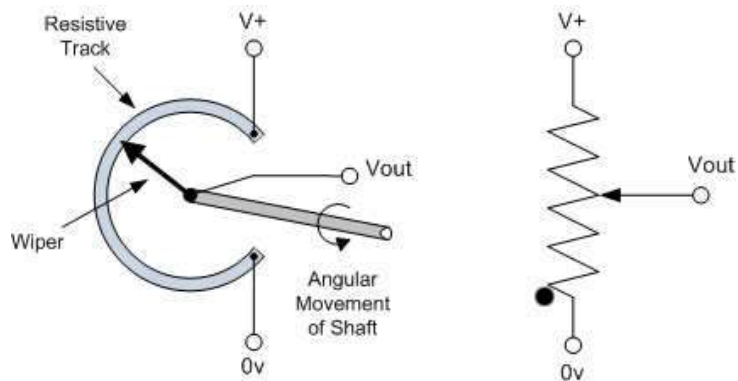

e454.eps

Change in measured physical variable (e.g. pressure, load, torque, position etc.) results in resistance of resistive sensors.



Sensor Calibration

- Calibration affords the opportunity to check the instrument against a known standard and subsequently to reduce errors in accuracy.
- Calibration process involves adjustment to compensate for the variation in:
 - Gain
 - Offset
 - Saturation
 - Hysteresis
 - Dead band
 - Drift in time

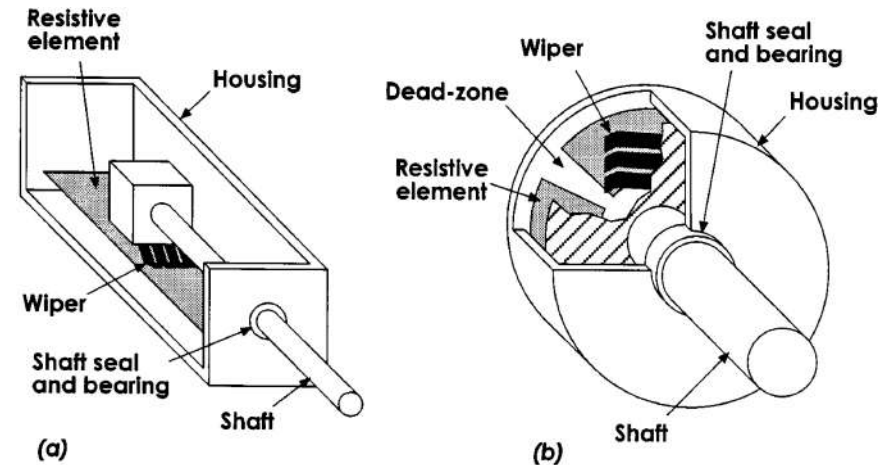

e663.eps

Typical linear and rotary potentiometers



Characteristics of Resistive Sensors

- Very simple device, also known as potentiometer or rheostat.
- Contains a resistance element that is contacted by a movable contact (or slide or wiper) to measure linear or angular displacement.
- Available commercially in many sizes, designs, ranges and prices.
- May be used to measure pressure, torque or force as it is possible to convert these to displacement by mechanical means.
- Electrical efficiency is very high and may provide sufficient output to permit control without any amplification.
- May be ac- or dc- excited.
- Because of friction life is limited and may generate noise.

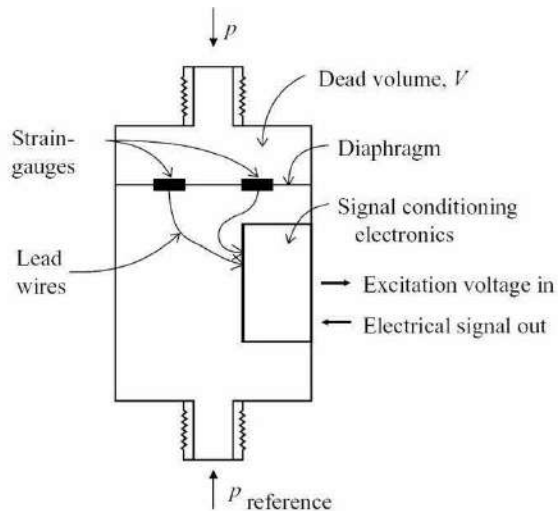

e473.eps

Pressure gauge using diaphragm and strain gauge

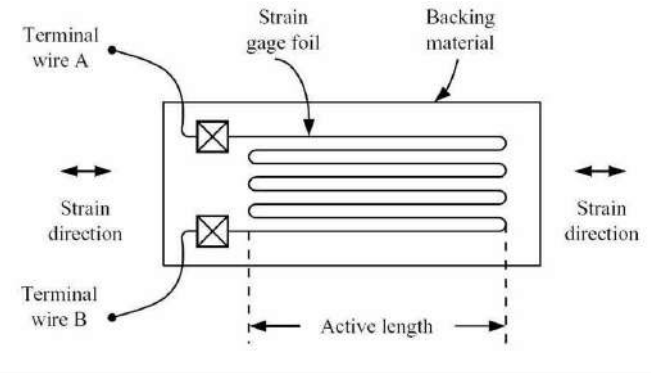

e468.eps

In strain gauge,

$$\frac{\Delta R}{R} = G \frac{\Delta L}{L} = \epsilon G$$

$$V_{out} = k_1 \frac{\Delta R}{R} = k_2 G$$

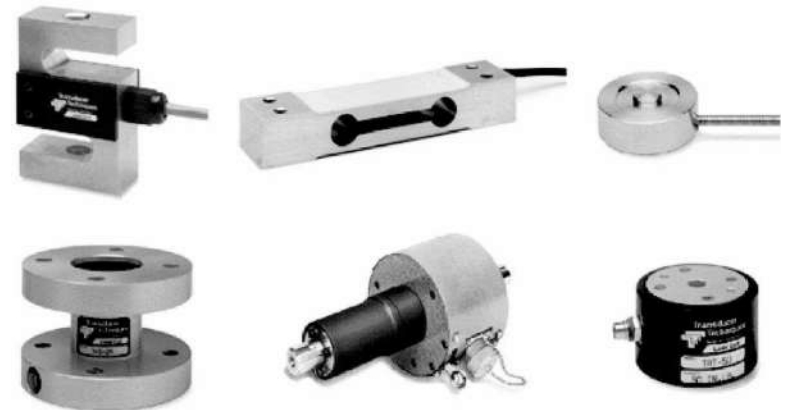

e470.eps

Various load cells using strain gauges for force and torque measurements



Inductive Sensors

$$v_L(t) = -L \frac{di}{dt} = -\frac{d\lambda}{dt} = -N \frac{d\phi}{dt}$$

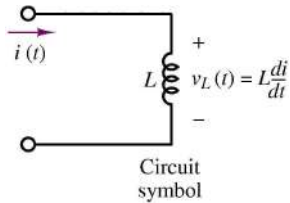

- Flux linkage, $\lambda = N\phi = Li$: amount of flux linking the N turns of coils, ϕ is the flux passing through the coil.
- Self inductance, L measures the voltage induced by the magnetic field generated by a current flowing in the circuit.

e436.eps

Electromagnetic induction is the creating of an emf in a conductor which is moving in a magnetic field, or is placed in a changing magnetic field. *Faraday's Law of Induction* states that an emf is induced on a circuit due to changing magnetic flux and the induced voltage opposes the change in the magnetic flux (*Lenz's Law*).



- In inductive transducers, a core moves linearly inside a transformer consisting of a center primary coil & two secondary coils.
- The secondary coils have equal number of turns & are connected in series opposing so that the emfs induced in the coils oppose each other. When core is centred voltage output is zero.
- When the core is moved off center, net voltage output varies linearly with core's position. When operating within linear range, it is known as *Linear Variable Differential Transformer (LVDT)*.

Applications:

Used to measure position, pressure, liquid level, vibration, acceleration & shock. May be configured to many kinds of specialized applications. The list includes standard, long-travel & miniature types, rotary variable differential transformers (RVDTs), high-temperature & cryogenic types, LVDTs designed for hostile environments, hermetically sealed, high-pressure, large-bore & nuclear-rated units.



LVDT: Linear Variable Differential Transformer

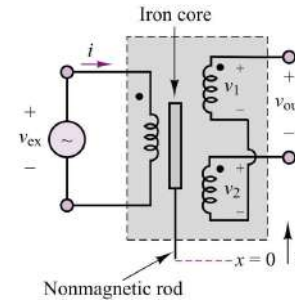

e637.eps

$$iR_p + L_p \frac{di}{dt} = V_{ex}$$

$$v_1 = M_1 \frac{di}{dt} \quad v_2 = M_2 \frac{di}{dt}$$

$$v_{out} = v_1 - v_2 = (M_1 - M_2) \frac{di}{dt}$$

M_1 & M_2 : mutual inductances

- Ferromagnetic core determines the magnetic coupling between primary and secondary coils.
- If core $\uparrow \rightsquigarrow$ more coupling between with top coil $\rightarrow v_{out} > 0$. At null position: $M_1 = M_2 \rightarrow v_{out} = 0$. In LVDT, $M_1 - M_2$ is linearly related to the core displacement.

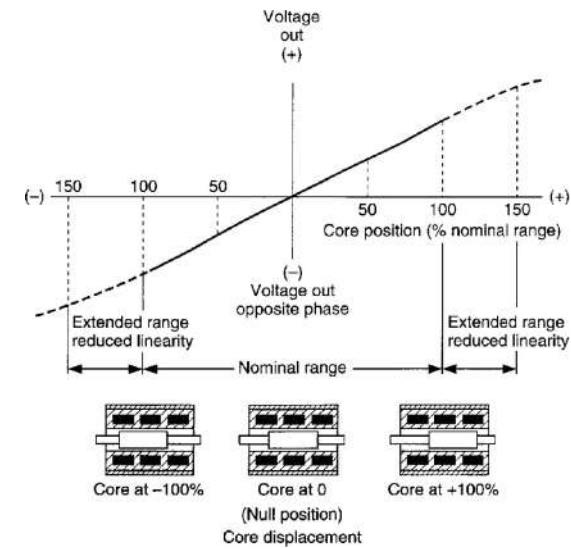

e638.eps

LVDT voltage & phase as a function of core position



LVDT Characteristics

Input

- ⊙ type : Linear displacement.
- ⊙ range : $\pm 0.1 - \pm 75$ mm.
- ⊙ impedance char. : Require $10^{-3} - 3 \cdot 10^{-3}$ N force.
- ⊙ sensitivity : 0.5% of total input range.

Output

- ⊙ type : Voltage \propto input displacement.
- ⊙ range : 16 – 160 mV/mm; $f \uparrow \rightarrow$ output \uparrow .
- ⊙ impedance char. : Mainly resistive; as low as 20 Ω .
- Frequency response : 50 Hz to 20 kHz. Applied frequency must be 10 times desired response.
- Temperature effects : Small influence; use thermistor to reduce.
- Error : Deviation from linearity is about 0.5%; generally accurate to 1.0%.



Capacitive Sensors

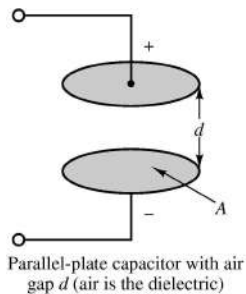

e433.eps

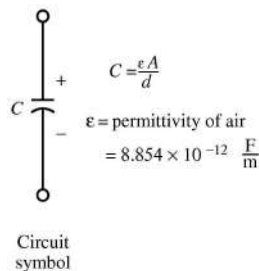

e434.eps

- Physical variable to be measured can be used to change in the capacitance by changing: (1) d , (2) A or (3) ϵ .
- Capacitance may be measured with bridge circuits. High-output impedance requires careful construction of output circuitry.
- Output impedance, Z of a capacitor is given by: $\Rightarrow Z = \frac{1}{2\pi fC}$



Advantages:

- Good accuracy, sensitivity and linearity
- Frictionless operation
- Ruggedness
- Physical, electrical and environmental isolation
- Cross-axis rejection
- Infinite resolution.

Disadvantages:

- Moving mass (inertia)
- Susceptible to stray ac magnetic fields
- Physical size
- Circuit requirements for full rated accuracy.

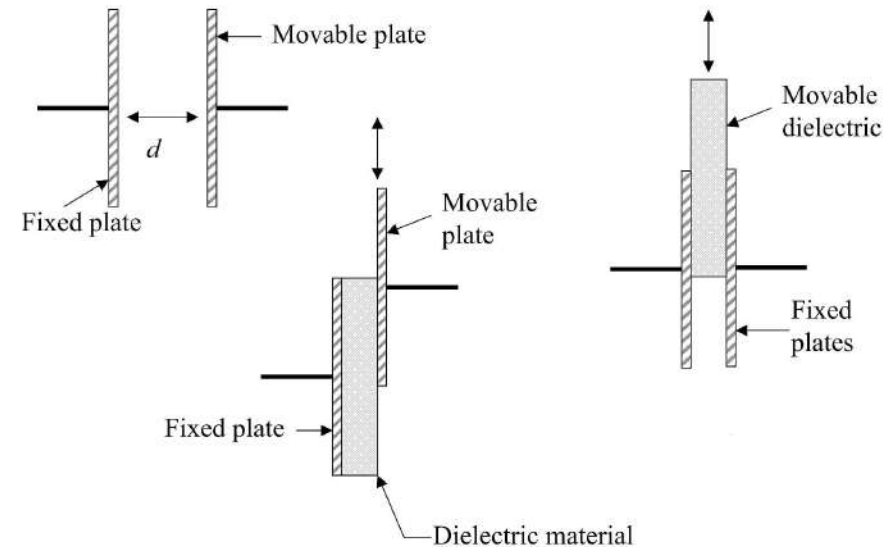

e654.eps



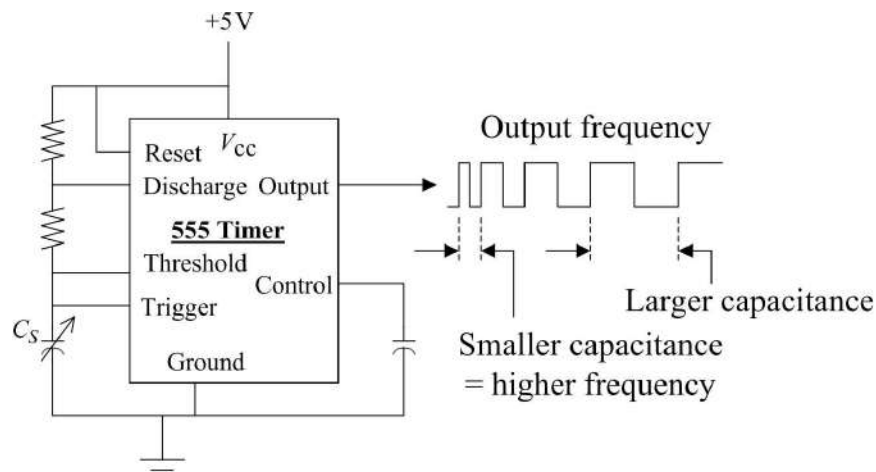

e656.eps

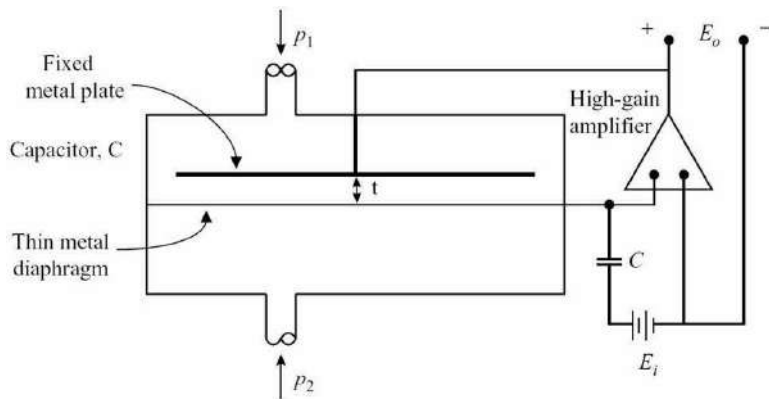

e474.eps

$$\Delta P \rightarrow t \rightarrow C \rightarrow E_o$$



Capacitive Transducer Characteristics:

Input

- type : Displacement, area or change in ϵ .
- range : Very broad; from $1\mu\text{m}$ to several meters.
- impedance char. : Require very small force, few dynes.
- sensitivity : Highly variable; can obtain 400 pF/mm .

Output

- type : Capacitance.
- range : Usually $10^{-3} - 10^3\text{ pF}$.
- impedance char. : Usually $10^3 - 10^7\Omega$.
- Frequency response : Depends on construction; up to 50 kHz .
- Temperature effects : Not strong if design allows for effects.

Applications:

- Pressure & force measurement
- Displacement measurement
- Proximity detectors
- Level measurements & switches
- Moisture & humidity measurement
- Tachometers
- Capacitive microphones (considered capable of the highest performance).

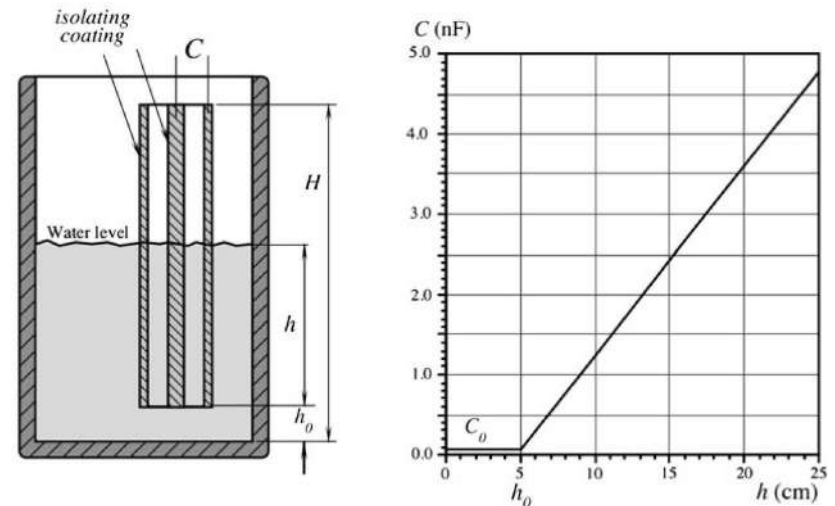

e664.eps

Capacitive water level sensor & typical capacitance as a function of water level



Piezoelectric transducers

Piezoelectric transducers involve a class of materials which, when mechanically deformed, produce an electric charge. The effect is *reversible* and applied usefully in both directions.

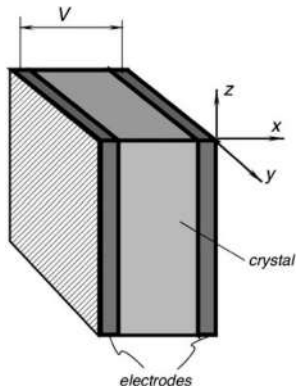

e652. eps

$$V = gtP = \left[\frac{d}{\epsilon} \right] tP$$

- V = Output voltage [V]
- g = Voltage sensitivity [V/N]
- d = Piezoelectric constant [C/N]
- F = Applied force [N]
- P = Applied pressure [Pa]

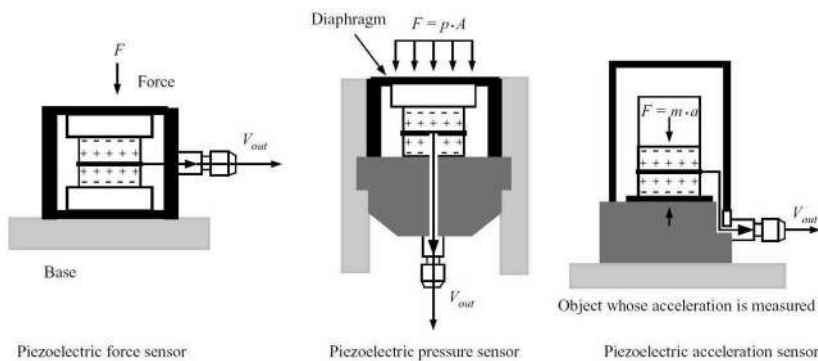

e653. eps

Applications: Used to measure: ⊙ Surface roughness ⊙ Strain
 ⊙ Force & torque ⊙ Pressure ⊙ Motion ⊙ Sound & noise.

Also used in: ⊙ Ultrasound NDT equipments ⊙ Sonar system
 ⊙ Ultrasound flow-meters ⊙ Small vibration shakers ⊙ Pumps for ink-jet printers ⊙ Micro-motion actuators.

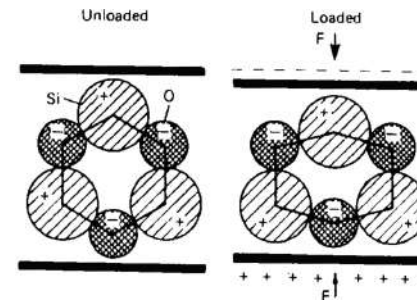

e668. eps

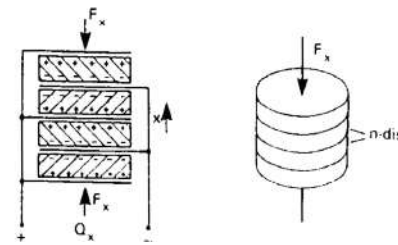
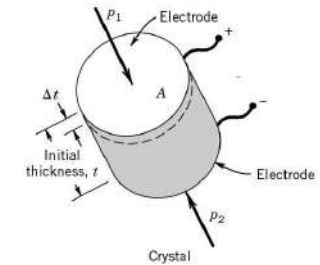

e667. eps

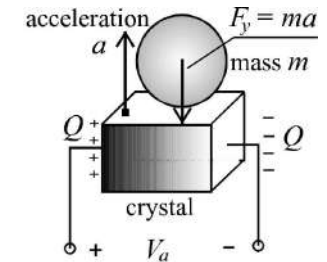

e662. eps

Piezoelectric materials: natural (quartz, rochelle salt) & synthetic crystals (lithium sulphate, ammonium dihydrogen phosphate), polarized ferroelectric ceramics (barium titanate & some polymer films).

Transducer Characteristics:

Input

- ⊙ type : Force or stress.
- ⊙ range : Varies widely with crystal material.
- ⊙ impedance char. : Input force required are relatively large.
- ⊙ sensitivity : Varies with material:
 - Quartz ~ 0.05 Vm/N.
 - Rochelle salt ~ 0.015 Vm/N.
 - Barium titanate ~ 0.007 Vm/N.

Output

- ⊙ type : Voltage proportional to input.
- ⊙ range : Wide, depends on crystal size & material.
- ⊙ impedance char. : High, of the order of $10^3 M\Omega$.
- Frequency response : 20- 20 kHz, no steady-state response.
- Temperature effects : Wide variation with temperature.



Photoemissive & Photoelectric Transducers

- Photoemissive transducers consist of a cathode-anode combination enclosed in a glass or quartz envelope, which is either evacuated or filled with an inert gas.
- In the proper circuit (usually a d.c. source from 100 - 200 V), light impingement on the cathode frees electrons to flow, thereby providing a small current given by: $\Rightarrow I = S\Phi$

$$I = \text{photoelectric currents}$$

$$\Phi = \text{illumination on cathode}$$

$$S = \text{sensitivity.}$$

- Photoelectric-tube response in different wavelength depends on:
 - ① Photo-emissivity of the cathode material ($0.2 - 0.8\mu\text{m}$).
 - ② Transmissivity of the glass-tube envelope.
 - Most glasses do not transmit light below about $0.4\mu\text{m}$.
 - Quartz transmits down to $0.2\mu\text{m}$.



Photovoltaic Cells

- Photovoltaic-cell (solar cell) consists of a metal base plate, a semiconductor material, and a thin transparent metallic layer. When light strikes the barrier between the transparent metal layer and the semiconductor material, a voltage is generated.
 - Si cells cover the visible & near-infra-red spectrum, intensities between $10^{-3} - 10^3 \text{ mW/cm}^2$.
 - Se cells accepts a spectrum of near-infra-red to ultraviolet, intensities between $10^{-1} - 10^2 \text{ mW/cm}^2$.
- The output of the device is strongly dependent on the load resistance R .
- The logarithmic behaviour of the cell is a decided advantage in such applications because of its sensitivity over a broad range of light intensities.
- Most widely used applications of the PVC include the light exposer meter in photographic work and solar radiation measurement.

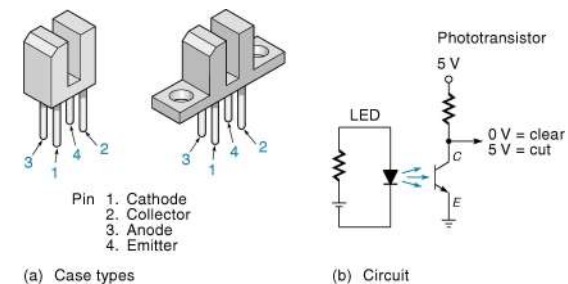

Photo-conductive/Photo-resistive Transducers

- Photo-conductive cells are elements whose conductivity is a function of the incident electromagnetic radiation. Commercially important materials are cadmium sulphide, germanium, and silicon.
- The essential elements of a photo-conductive cell are the ceramic substrate, a layer of photo-conductive material, metallic electrodes and a moisture-resistant enclosure.
- Lead-sulphide cell is widely used for detection of thermal radiation in the wavelength band of $1 - 3\mu\text{m}$. By cooling the detector higher wavelength ($= 4 - 5\mu\text{m}$) can be achieved.
- The spectral response of CdS cell closely matches that of human eye, and the cell is often used in applications where human vision is a factor.



Phototransistor Sensors



e459.eps

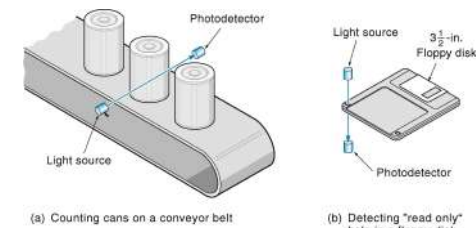

e460.eps



Hall Effect Sensor

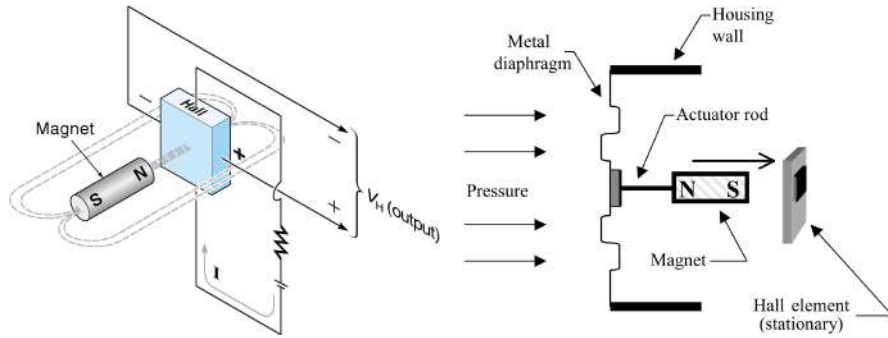

e458 .eps

e657 .eps

$$V_H = K_H \frac{IB}{t}$$

V_H = Hall-effect voltage K_H = constant
 B = magnetic flux-density I = current
 t = thickness constant

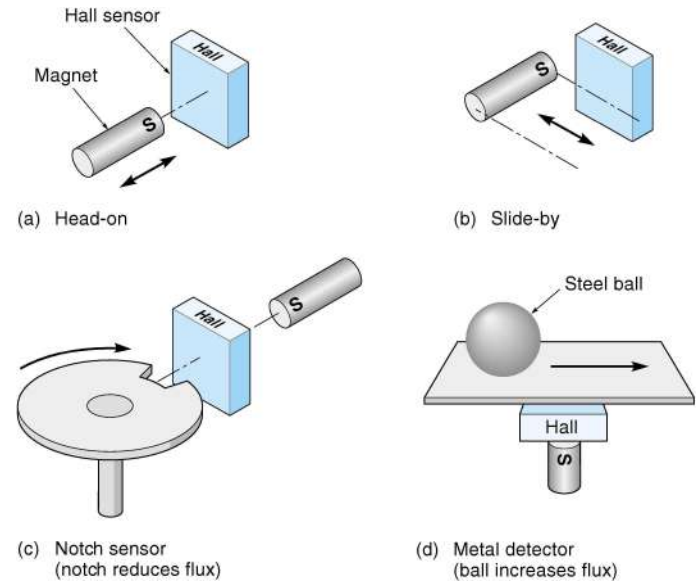

e457 .eps

